

Interaction Design

Chapter 12 (July 02, 2014, 9am-12pm):
IxD for Communities (Service Design Continued)

Recap Day 10:



People, Places, Products...

source: [3]



Processes and Performance

source: [3]

Processes

- the process describes “how” the service is ordered, created and delivered to the user
- processes can change subtle or radically within the service through different environments and over time
- often there are multiple pathways and therefore processes through a service experience

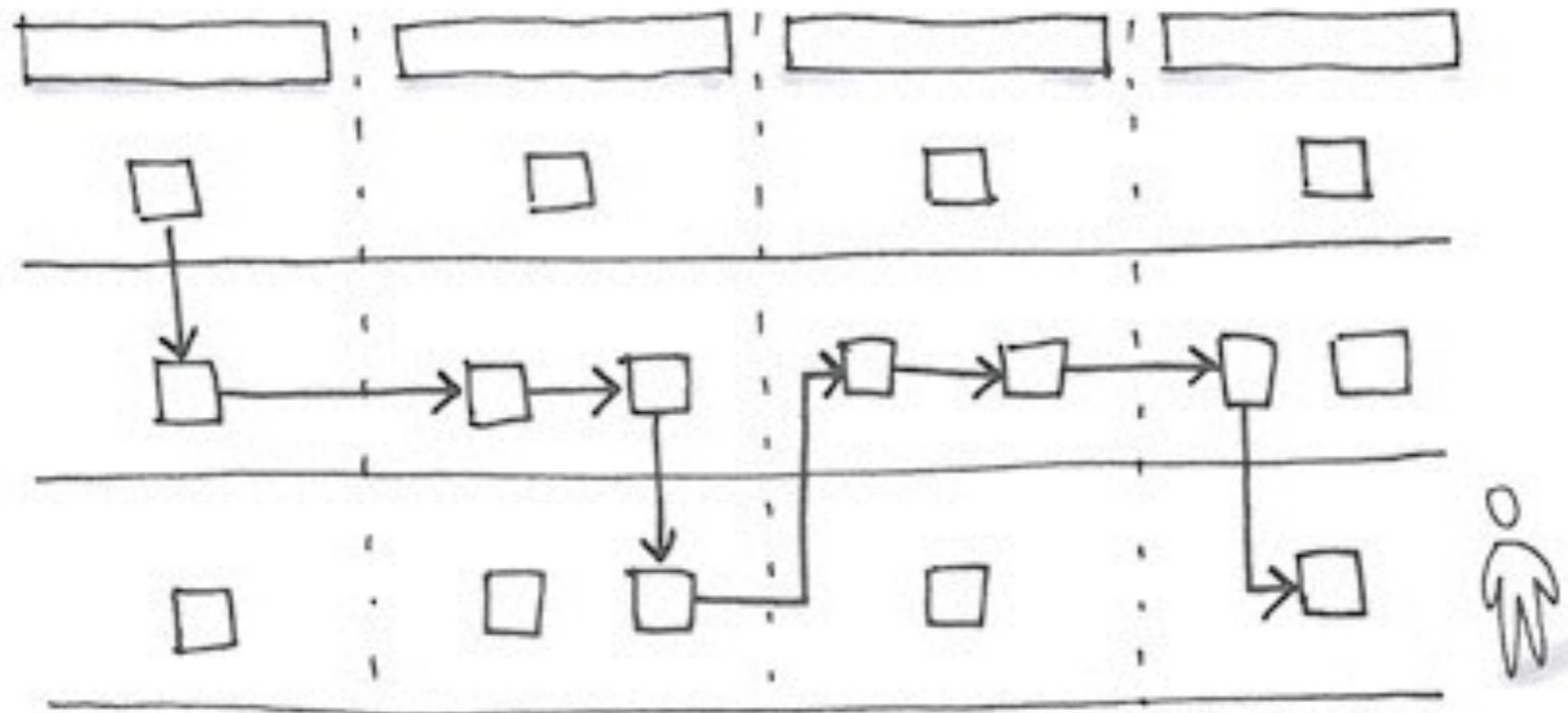

source: [5]

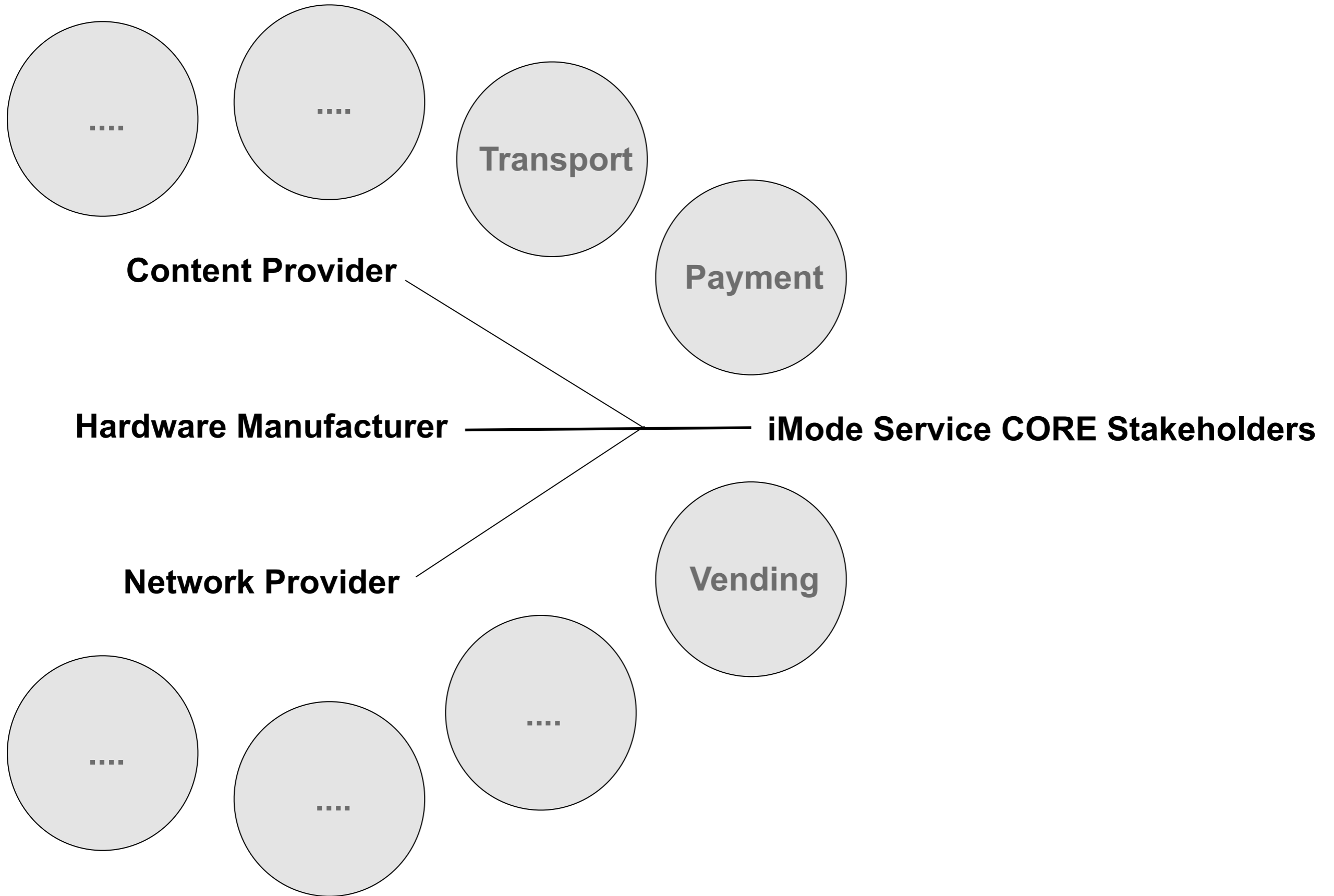

What is a service?

- a chain of activities that form a process and have value for the end user
(**customer journey**)
- services affect our daily quality of life
(**user experience**)
- service design is somehow similar to systems design (Chapter 2)
(**service blueprints**)
- service design focuses on the entire system of use
(**via touchpoints**)

Service design can involve

person2person interaction = check in desk

person2machine interaction = self check in kiosk

machine2machine interaction = airport baggage system

Service as Design Triangle:

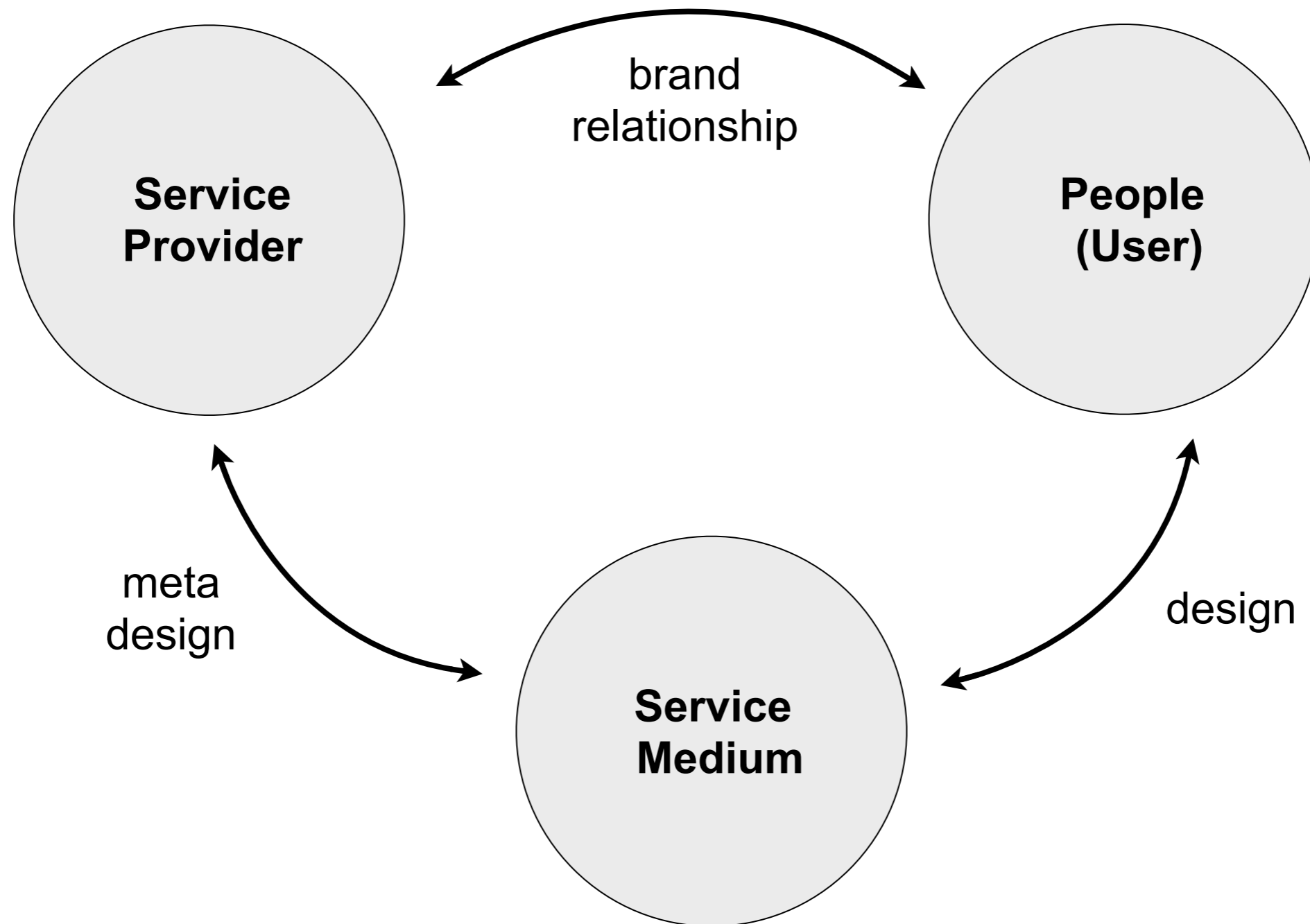

Service design addresses the functionality and form of the service medium. The aim is to ensure that service interfaces are **usable** and **useful, effective and efficient, desirable and differentiated** from the provider and the persons point of view.

after Birgit Mager

What is an Experience Blueprint?

An experience blueprint is a diagrammatic representation of the user journey that maps processes, touch points, people and support activities involved in creating the experience.

It helps in visualising the correlation between the front stage (user end) and the back stage (provider end). It also helps to interconnect the tangible elements with intangible and deal with them more objectively.

Front Stage

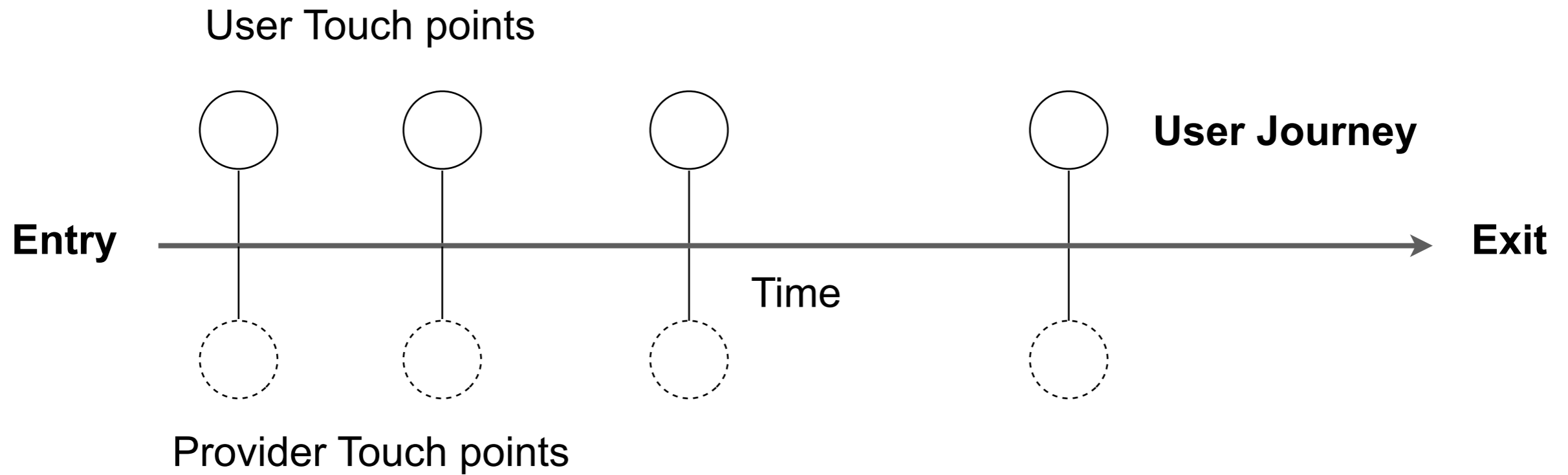

Support Processes

Back Stage

source: [2]

Interaction Design

Chapter 12 (July 02, 2014, 9am-12pm):
IxD for Communities (Service Design Continued)

About the Book ShareThis

Mainstream media, often known simply as MSM, have not yet disappeared in a digital takeover of the media landscape. But the long-dominant MSM—television, radio, newspapers, magazines, and books—have had to respond to emergent digital media.

Newspapers have interactive Web sites; television broadcasts over the Internet; books are published in both electronic and print editions. In *Designing Media*, [Bill Moggridge](#) examines connections and conflicts between old and new media, describing how the MSM have changed and how new patterns of media consumption are emerging.

The book features interviews with thirty-seven people who have made significant creative contributions to the design and development of media, ranging from the publisher of the *New York Times* to the founder of Twitter. We learn about innovations that rely on contributions from a crowd (or a community), as told by Wikipedia's [Jimmy Wales](#) and Craigslist's [Craig Newmark](#); how the band [OK Go](#) built a following using YouTube; how real-time connections between dispatchers and couriers inspired [Twitter](#); how a [BusinessWeek](#) blog became a quarterly printed supplement to the magazine; and how e-readers have evolved. [Ira Glass](#) compares the intimacy of radio to that of the Internet; the producer of PBS's [Frontline](#) supports the program's investigative journalism by putting documentation of its findings online; and the developers of [Google's Trendalyzer](#) software describe its beginnings as animations that accompanied lectures about social and economic development in rural Africa.



<http://www.designing-media.com/>

Designing Media

- The Vision of Designing Media
- Designing for Communities
- Branding and Design

Paul Saffo

**is a media futurist
and professor at Stanford University**

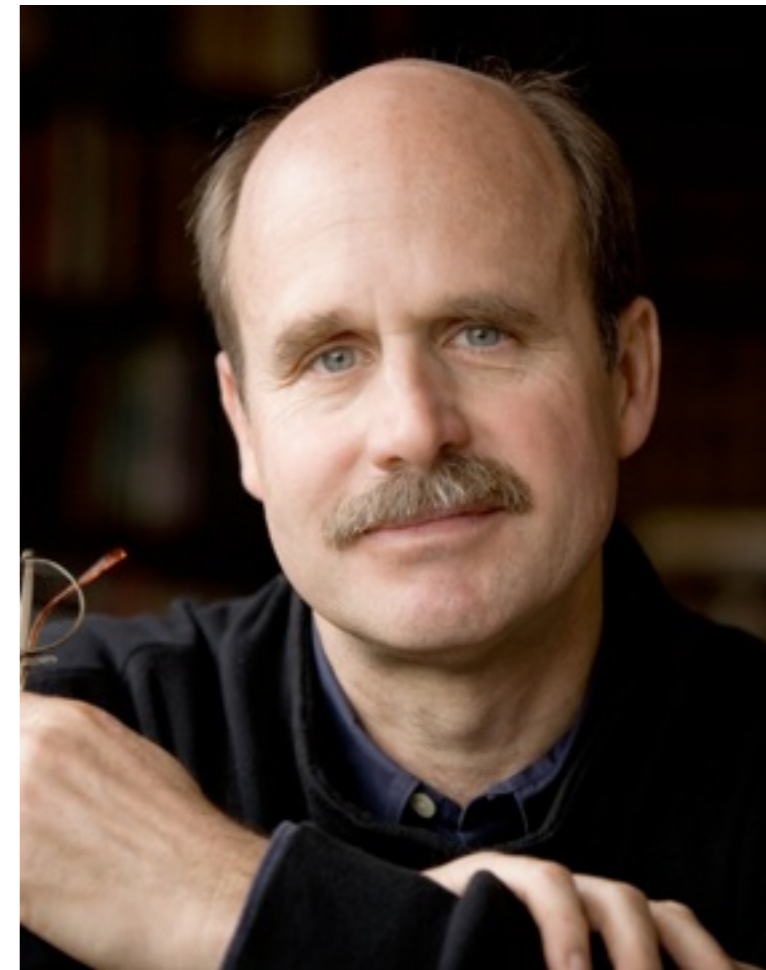



- shift from an information to a media world
- mass media to personal media
- towards participatory media > there is a need for participation
- economy where every single act is an act of creation
> result
- this changes economy
- the amount of participation with media affects the economic situation

source: [1]

...different media invite different degrees of participation on the part of a person who chooses to consume a medium.

Marshall McLuhan



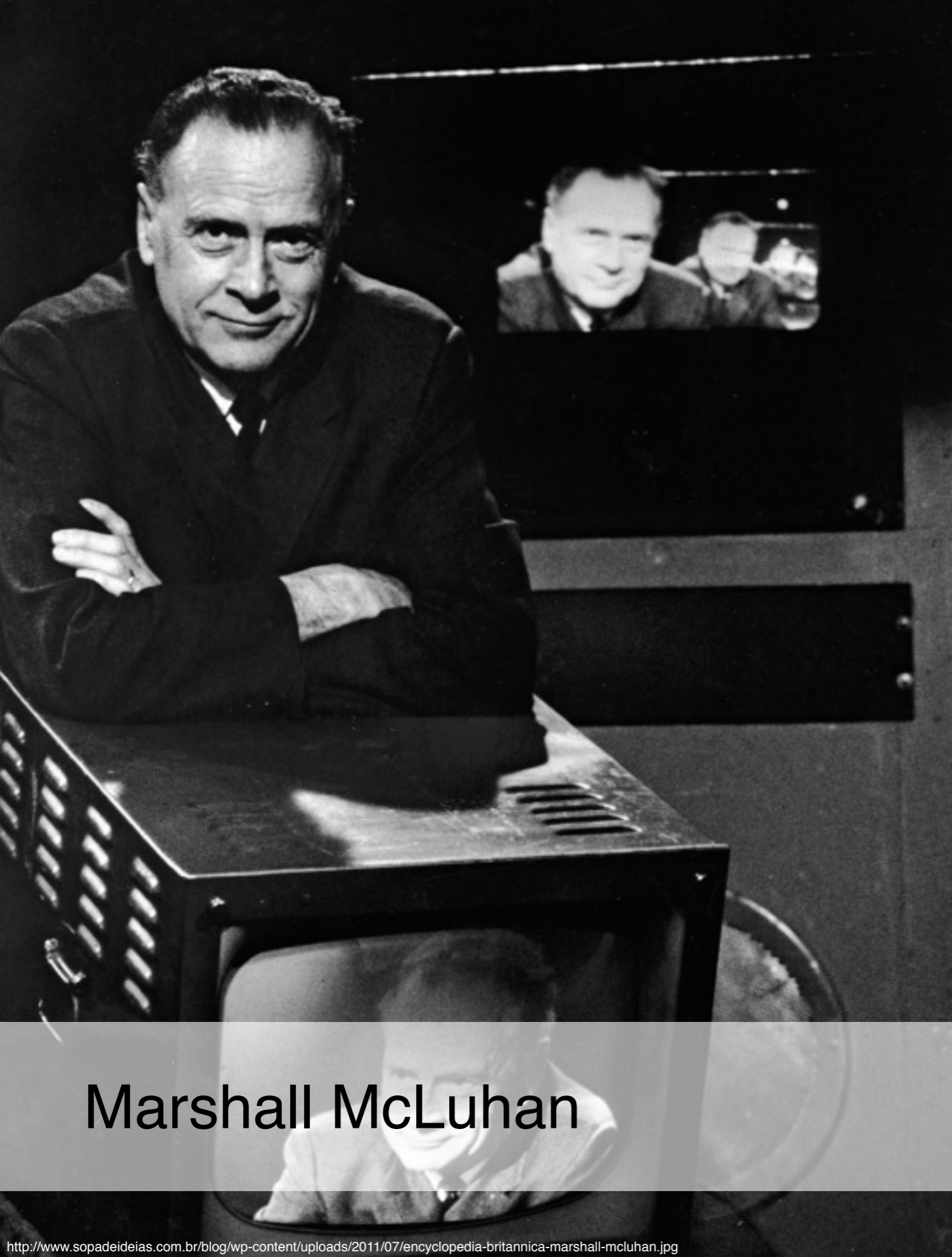

Marshall McLuhan

"Any hot medium allows of less participation than a cool one, as a lecture makes for less participation than a seminar, and a book for less than a dialogue."

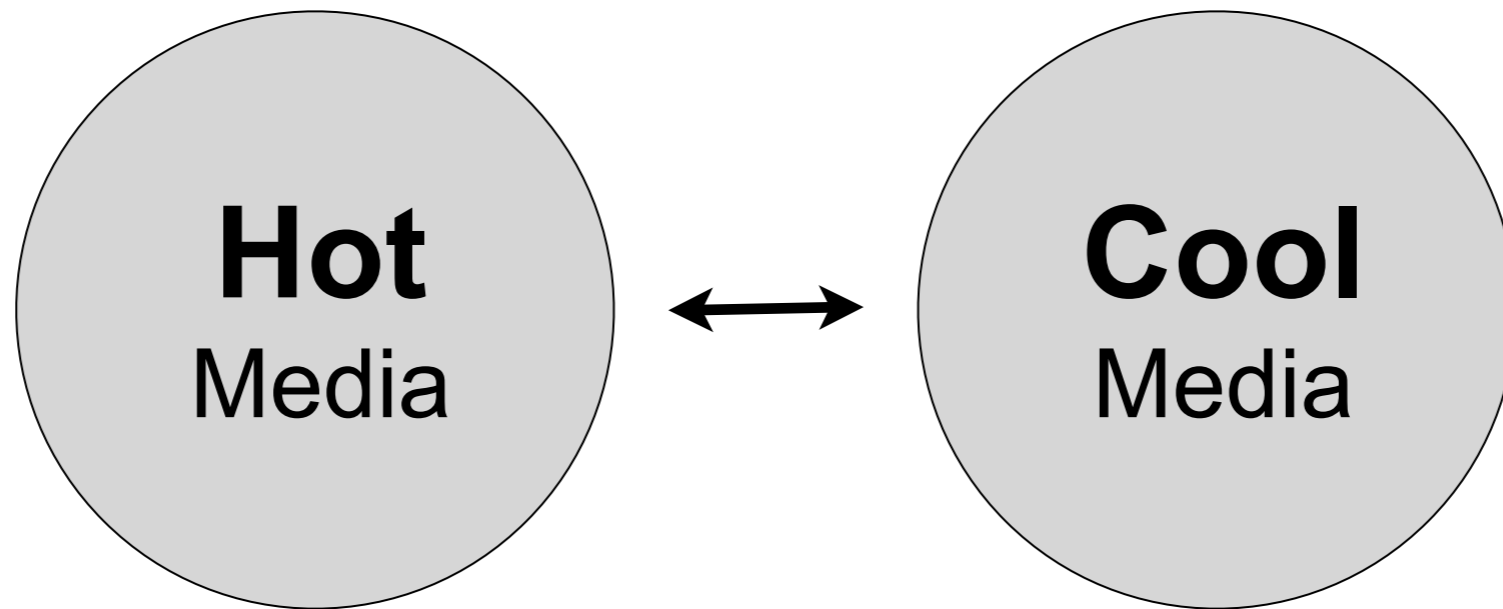

Interaction Design Paradigms

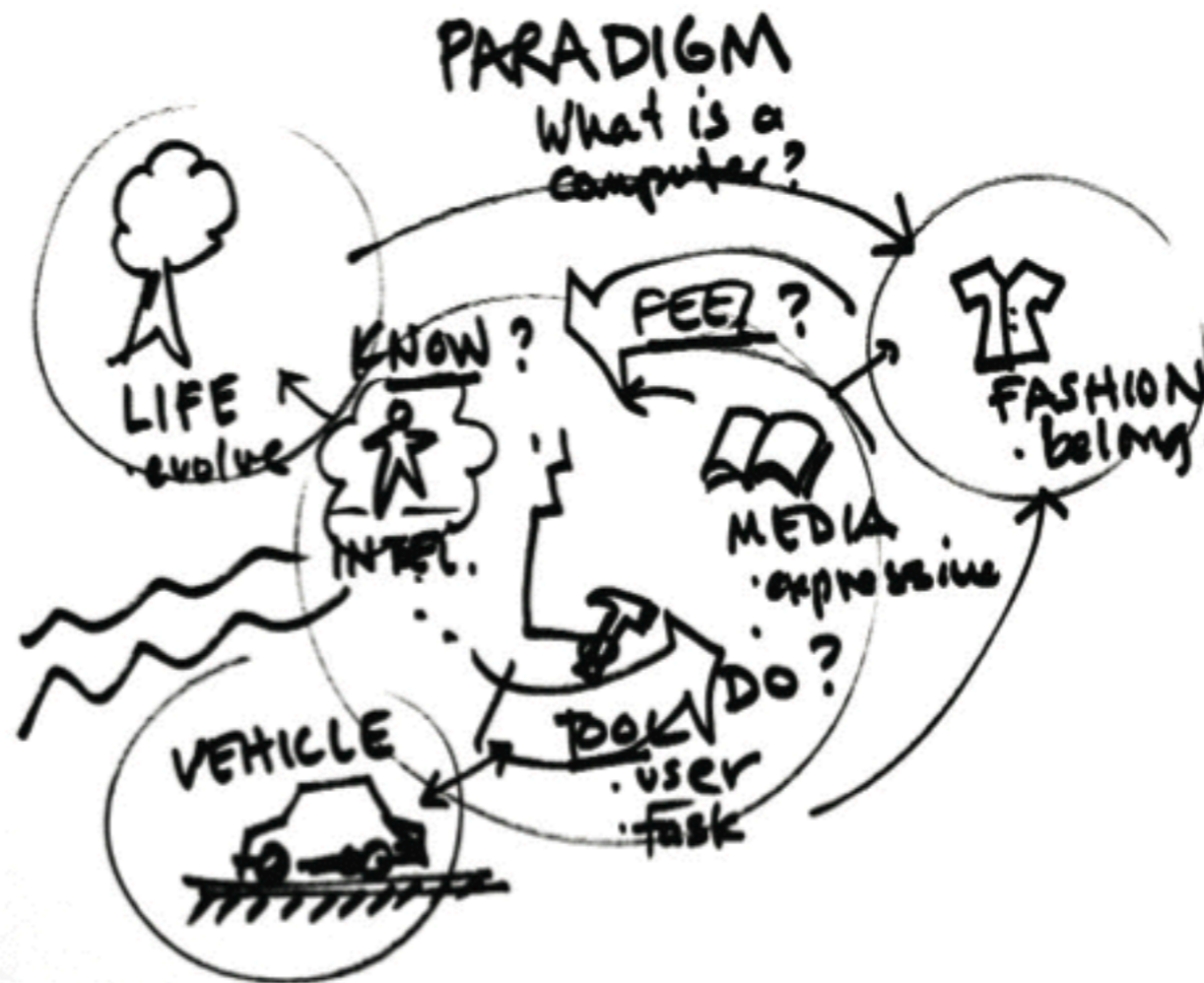

A paradigm is an example that serves as a pattern for the way people think about something.

It is the set of questions that a particular community has decided are important. For interaction design there is often some confusion about what paradigm you are working with.

source: [3]

Designing Media

- The Vision of Designing Media
- Designing for Communities
- Branding and Design



WIKIPEDIA

The Free Encyclopedia

“What is it that people are going to be doing that they’ll find fun, and how do we make it interesting?”

Jimmy Wales

source: [4]



- top down vs. bottom up approach
- don't design systems around the worst people
- design systems around the core of the good people

source: [4]

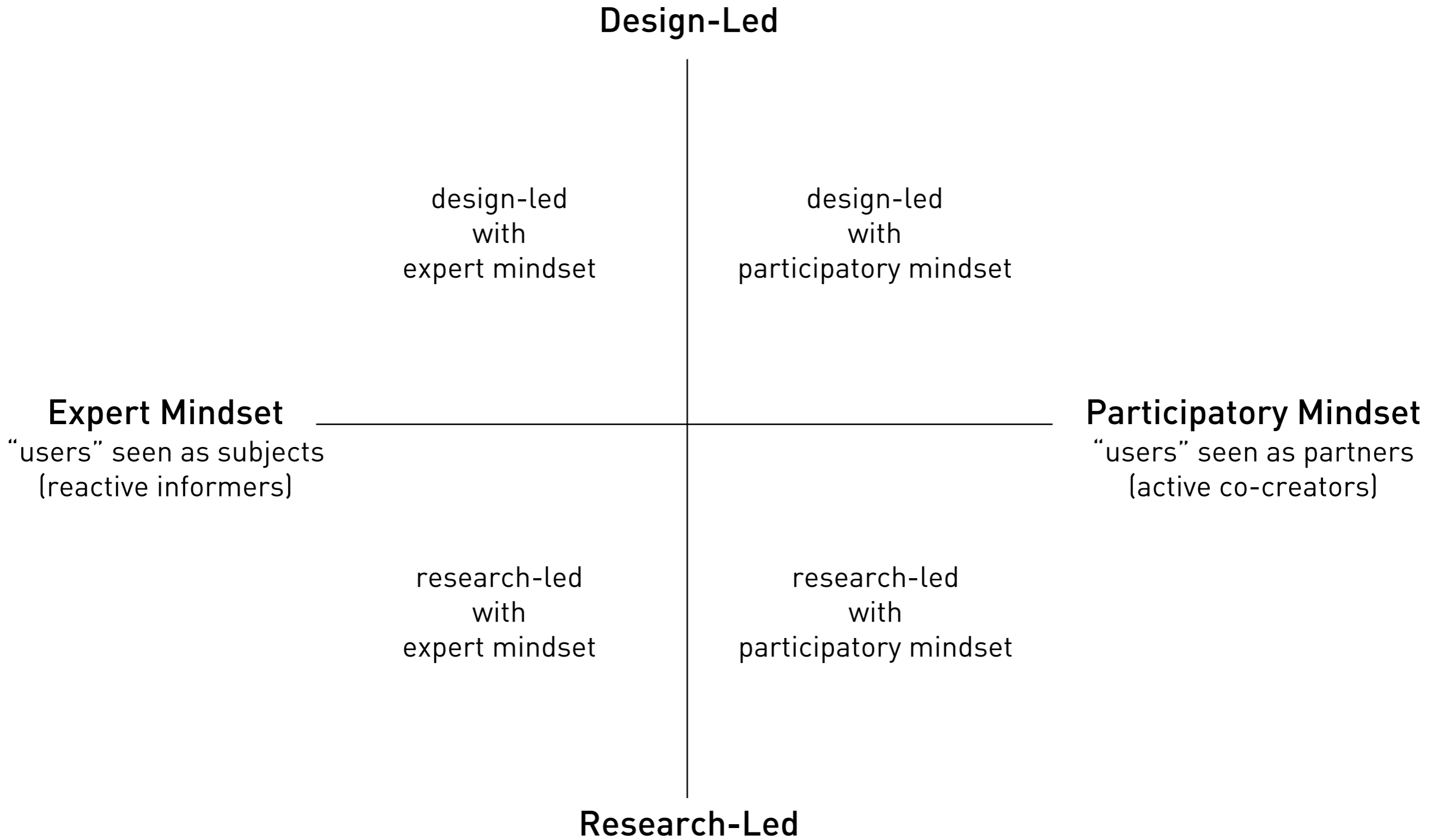

source: [6+7]

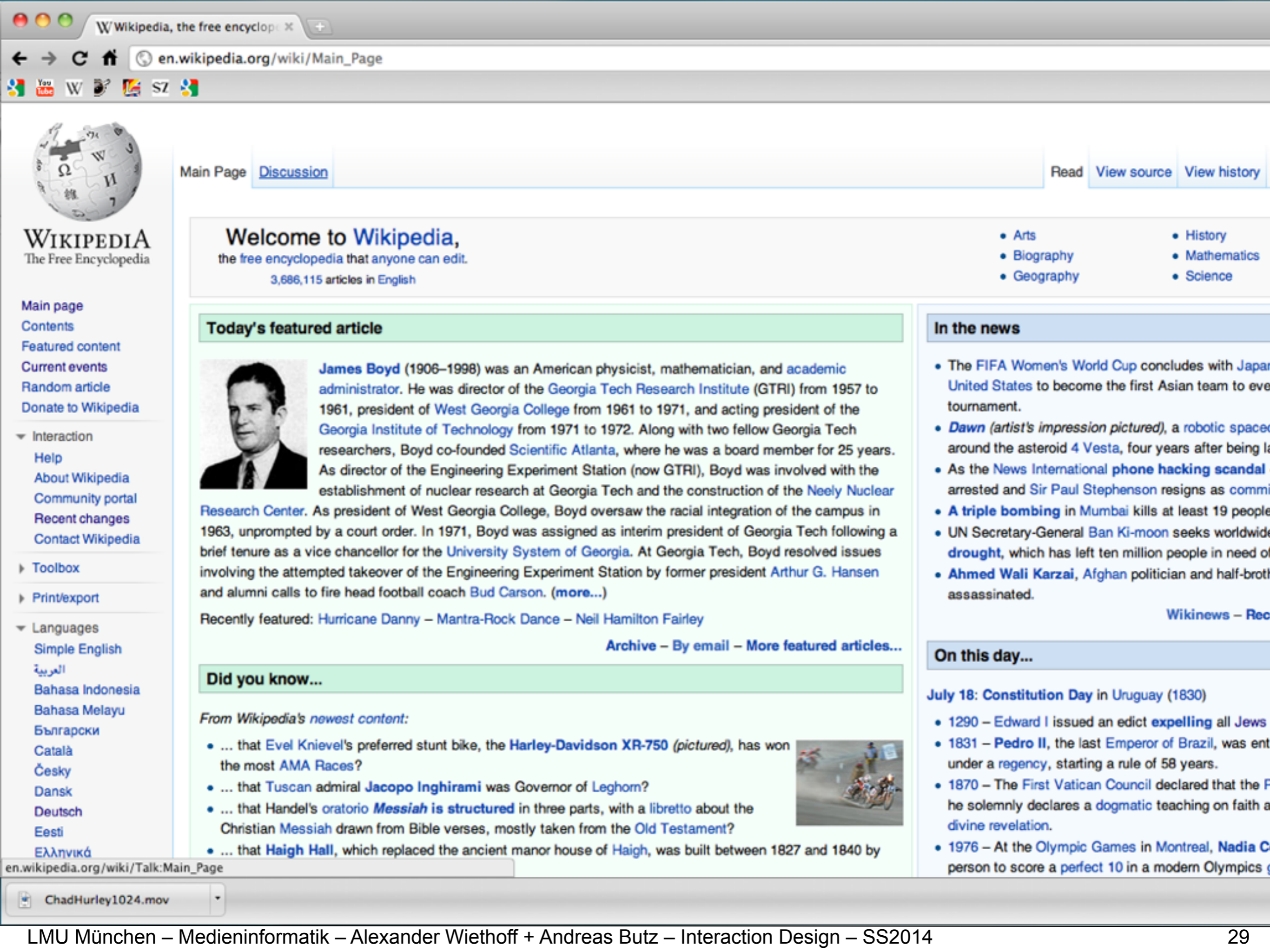

WIKIPEDIA
The Free Encyclopedia

- Main page
- Contents
- Featured content
- Current events
- Random article
- Donate to Wikipedia

- Interaction
 - Help
 - About Wikipedia
 - Community portal
 - Recent changes
 - Contact Wikipedia

- Toolbox
- Print/export

- Languages
 - Simple English
 - العربية
 - Bahasa Indonesia
 - Bahasa Melayu
 - Български
 - Català
 - Česky
 - Dansk
 - Deutsch
 - Eesti
 - Ελληνικά

Main Page [Discussion](#)

[Read](#) [View source](#) [View history](#)

Welcome to **Wikipedia**,
the free encyclopedia that anyone can edit.
3,686,115 articles in English

- Arts
- Biography
- Geography
- History
- Mathematics
- Science

Today's featured article



James Boyd (1906–1998) was an American physicist, mathematician, and academic administrator. He was director of the [Georgia Tech Research Institute](#) (GTRI) from 1957 to 1961, president of [West Georgia College](#) from 1961 to 1971, and acting president of the [Georgia Institute of Technology](#) from 1971 to 1972. Along with two fellow Georgia Tech researchers, Boyd co-founded [Scientific Atlanta](#), where he was a board member for 25 years. As director of the Engineering Experiment Station (now GTRI), Boyd was involved with the establishment of nuclear research at Georgia Tech and the construction of the [Neely Nuclear Research Center](#). As president of West Georgia College, Boyd oversaw the racial integration of the campus in 1963, unprompted by a court order. In 1971, Boyd was assigned as interim president of Georgia Tech following a brief tenure as a vice chancellor for the [University System of Georgia](#). At Georgia Tech, Boyd resolved issues involving the attempted takeover of the Engineering Experiment Station by former president [Arthur G. Hansen](#) and alumni calls to fire head football coach [Bud Carson](#). [\(more...\)](#)

Recently featured: [Hurricane Danny](#) – [Mantra-Rock Dance](#) – [Neil Hamilton Fairley](#)

[Archive](#) – [By email](#) – [More featured articles...](#)

Did you know...

From Wikipedia's *newest content*:

- ... that [Evel Knievel's](#) preferred stunt bike, the [Harley-Davidson XR-750](#) *(pictured)*, has won the most [AMA Races](#)?
- ... that [Tuscan](#) admiral [Jacopo Inghirami](#) was Governor of [Leghorn](#)?
- ... that Handel's oratorio *[Messiah is structured](#)* in three parts, with a [libretto](#) about the Christian [Messiah](#) drawn from Bible verses, mostly taken from the [Old Testament](#)?
- ... that [Haigh Hall](#), which replaced the ancient manor house of [Haigh](#), was built between 1827 and 1840 by



In the news

- The [FIFA Women's World Cup](#) concludes with [Japan](#) and [United States](#) to become the first Asian team to ever win a tournament.
- *[Dawn](#)* (*artist's impression pictured*), a [robotic spacecraft](#) around the asteroid [4 Vesta](#), four years after being launched.
- As the [News International phone hacking scandal](#) continues, [Gordon Brown](#) is arrested and [Sir Paul Stephenson](#) resigns as [Commissioner of the Met](#).
- [A triple bombing](#) in [Mumbai](#) kills at least 19 people and injures 100.
- UN Secretary-General [Ban Ki-moon](#) seeks worldwide action on [drought](#), which has left ten million people in need of food.
- [Ahmed Wali Karzai](#), Afghan politician and half-brother of [Hamid Karzai](#), is assassinated.

[Wikinews](#) – [Recent changes](#)

On this day...

July 18: Constitution Day in [Uruguay](#) (1830)

- 1290 – [Edward I](#) issued an edict **expelling** all [Jews](#) from [England](#).
- 1831 – [Pedro II](#), the last Emperor of [Brazil](#), was enthroned under a [regency](#), starting a rule of 58 years.
- 1870 – The [First Vatican Council](#) declared that the Pope can **excommunicate** and he solemnly declares a [dogmatic](#) teaching on faith and morals as [divine revelation](#).
- 1976 – At the [Olympic Games in Montreal](#), [Nadia Comăneci](#) became the first person to score a **perfect 10** in a modern Olympic sport.

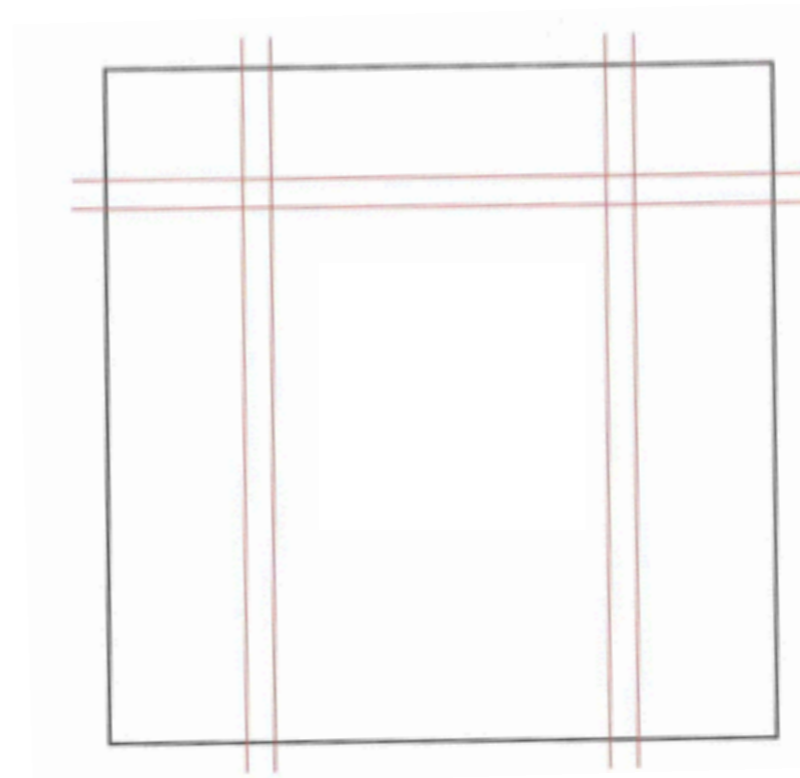
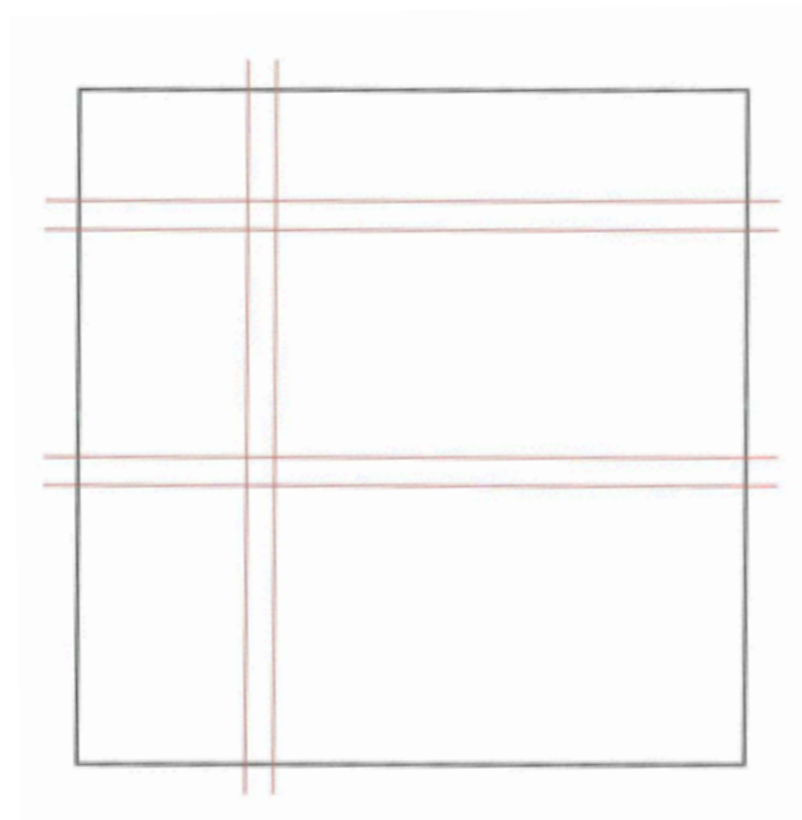
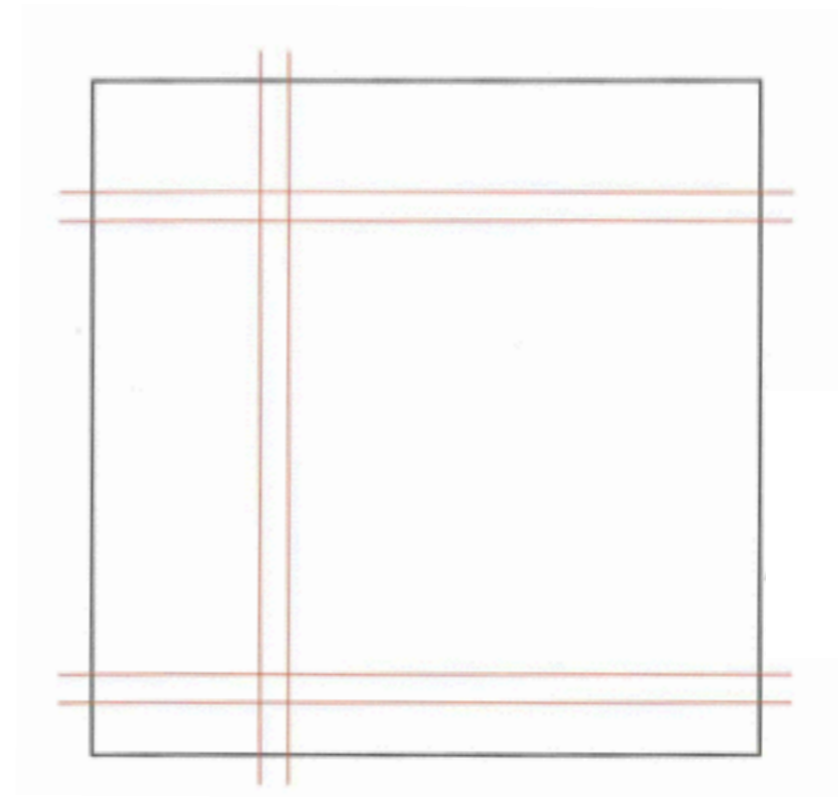
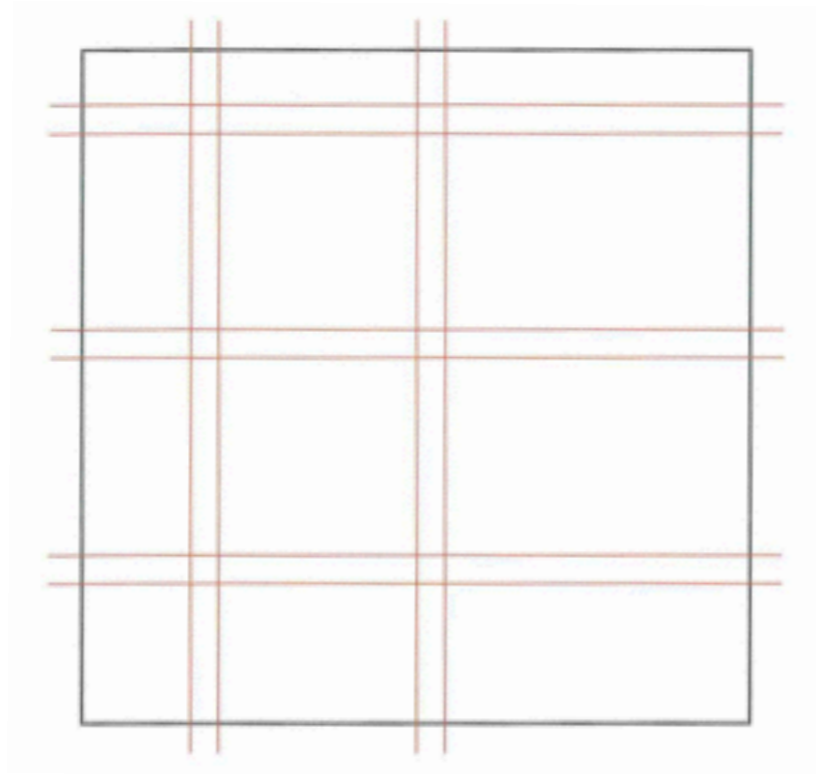

source : [4]

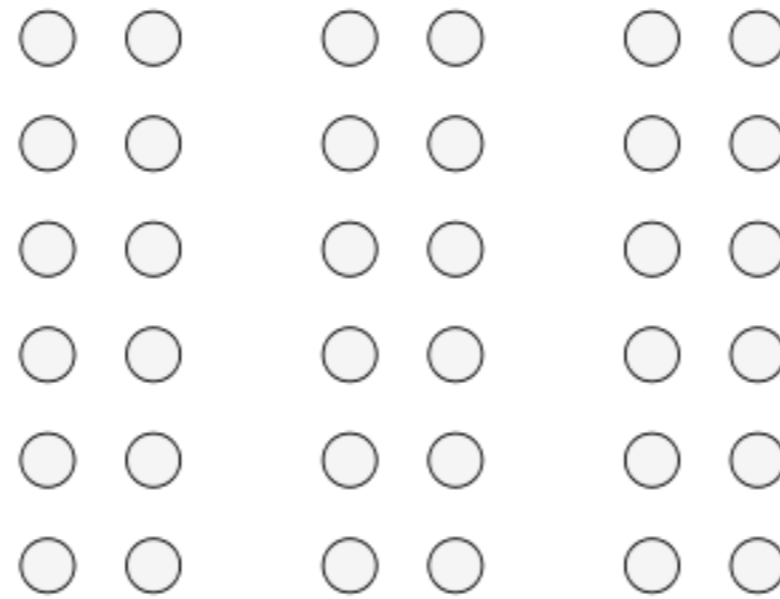
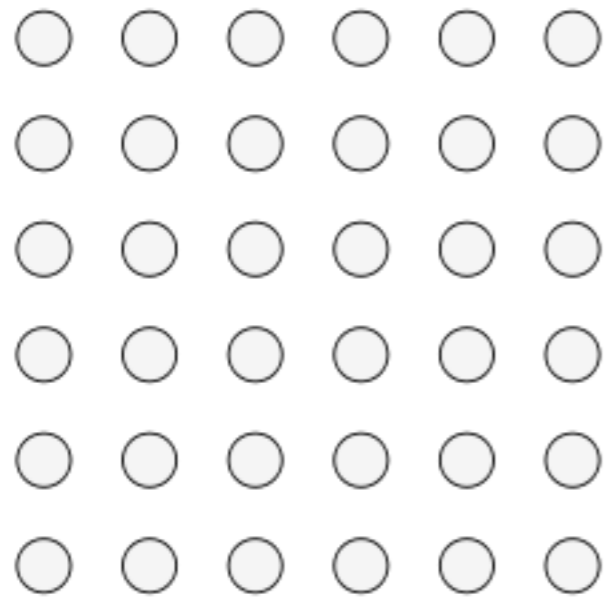

Proximity & Grouping





- small incremental changes
- maintain simplicity
- listen to people and do something
- provide good customer service
- enable volunteering
- increased service engagement

craigslist^{de}

In 'Kleinanzeigen' veröffentlichen

[Mein Konto](#)

[Hilfe/FAQ/Missbrauch/Rechtsws](#)

craigslist durchsuchen

Zum Verkauf

Ereigniskalender

M	D	M	D	F	S	S
18	19	20	21	22	23	24
25	26	27	28	29	30	31
1	2	3	4	5	6	7
8	9	10	11	12	13	14

Scams & Betrug vermeiden

Tipps zur eigenen Sicherheit

[craigslist-Blog](#)

[craigslist-Datenblatt](#)

[Craigslist-Best-Of](#)

[craigslist TV](#)

[craigslist - Film & DVD](#)

[craigslist-Stiftung](#)

[craigconnects](#)

[Systemstatus](#)

[AGB](#) [Impressum](#)

[Datenschutz](#) [Hilfe](#)

München

Community

- [Aktivitäten](#)
- [Allgemein](#)
- [Ereignisse](#)
- [Freiwillige](#)
- [Fundsachen](#)
- [Gruppen](#)
- [Haustiere](#)
- [Kinderbetreuung](#)
- [Künstler](#)
- [Mitfahrgelegenheit](#)
- [Musiker](#)
- [Neuigkeiten/Gegend](#)
- [Politik](#)
- [Unterricht](#)

Persönliches

- [rein platonisch](#)
- [Sie sucht Sie](#)
- [Sie sucht Ihn](#)
- [Er sucht Sie](#)
- [Er sucht Ihn](#)
- [Bunt gemischt](#)
- [Zwanglose Treffen](#)
- [Verpasste Gelegenheiten](#)
- [Erfreuliches und Unerfreuliches](#)

Diskussionsforen

- | | | |
|----------------------------------|-----------------------------|--------------------------------|
| 1099 | Gesund | Reparatur |
| Anders | Haiku | RoFo |
| Apple | Haustiere | Scheidung |
| Atheist | Heirat | Shopping |
| Autoren | Hilfe | Sie-Sie |
| Autos | Homo | Sparsam |
| Bikes | Jobs | Spielen |
| Bildung | K.handwrk | Sport |
| Comp | Kosmetik | Sterben |
| Diät | Kunst | Steuern |
| Eltern | LZB | TV |
| Er-Ihn | Linux | Tests |
| Essen | LokPol | Transsexuelle |
| Ethnische Gruppe | Motorrad | Unterkünfte |
| Etikette | Musik | Vegan |
| Feedbk | Natur | Verlauf |
| Film | PeFo | Wein |
| Fitness | Philosophie | Wissenschaften |
| Frauen | Politik | Witze |
| | Promis | Wörter |

Unterkünfte

- [Büro/Handel](#)
- [Ferienwohnungen](#)
- [Immo gesucht](#)
- [Immobilie zum Verkauf](#)
- [Immobilientausch](#)
- [Parken/Lagerung](#)
- [Untervermietungen](#)
- [Wohnungen / Unterkünfte](#)
- [Zimmer/Beteiligungen/WGs](#)

Zum Verkauf

- | | |
|---------------------------|------------------------------------|
| Allgemein | Antiquitäten |
| Autoteile | Autos+LKWs |
| Bikes | Babys+Kinder |
| Boote | CDs/DVDs/Videos |
| Bücher | Elektronik |
| Computer | Foto+Video |
| Gesucht | Haushaltsgeräte |
| Handys | Hof+Garten |
| Haushalt | Kleidung+Acc |
| Material | Kosmetik+gesund |
| Möbel | Kostenlos |
| Sammeln | Kunst+Handwerk |
| Schmuck | Motorräder |
| Sport | Musikinstrumente |
| Tausch | Privater Flohmarkt |
| Tickets | Spielzeug+Spiele |
| Werkzeug | Unternehmen |
| Wohnwägen | Videospielen |

Dienstleistungen

- | | |
|--------------------------|----------------------------------|
| Auto | Anzeigen Klein |
| Computer | Fahrradfahren |
| Ereignis | Haustier |
| Finanzen | Hof+Garten |
| Handwerk | Immobilien |
| Haushalt | Rechtswesen |
| Kosmetik | Reise/Urlaub |
| Kreativ | Schreib/Übersetz |

Jobs

- [Arbeitskräfte allgemein](#)
- [Architektur/Ingenieurswesen](#)
- [Bildung](#)
- [Biotech/Wissenschaft](#)
- [Buchhaltung+Finanzen](#)
- [Einzelhandel/Großhandel](#)
- [Fernsehen/Film/Video](#)
- [Fertigung](#)
- [Gastronomie/Gastgewerbe](#)
- [Gemeinnütziger Sektor](#)
- [Handwerk/Kunsthandwerk](#)
- [Immobilien](#)
- [Internet-Techniker](#)
- [Kundenservice](#)
- [Kunst/Medien/Design](#)
- [Marketing/PR/Werbung](#)
- [Medizin/Gesundheitswesen](#)
- [Personal](#)
- [Rechtswesen](#)
- [Regierung](#)
- [Salon/Spa/Fitness](#)
- [Schreiben/Lektorat](#)
- [Sicherheit](#)
- [Software/QS/Datenbank](#)
- [Systeme/Netzwerke](#)
- [Technischer Support](#)
- [Transport](#)
- [Unternehmen/Management](#)
- [Vertrieb/Geschäftsentw.ng](#)
- [Verwaltung/Büro](#)
- [Web-/Informationsdesign](#)
- [\[USW\]](#)
- [\[Teilzeit \]](#)

Aushilfsjobs

- | | |
|--------------------------|------------------------------------|
| Computer | Arbeitskräfte |
| Ereignis | Häuslicher Bereich |
| Kreativ | Künstler.Schaffnd |
| Personal | Schreiben |

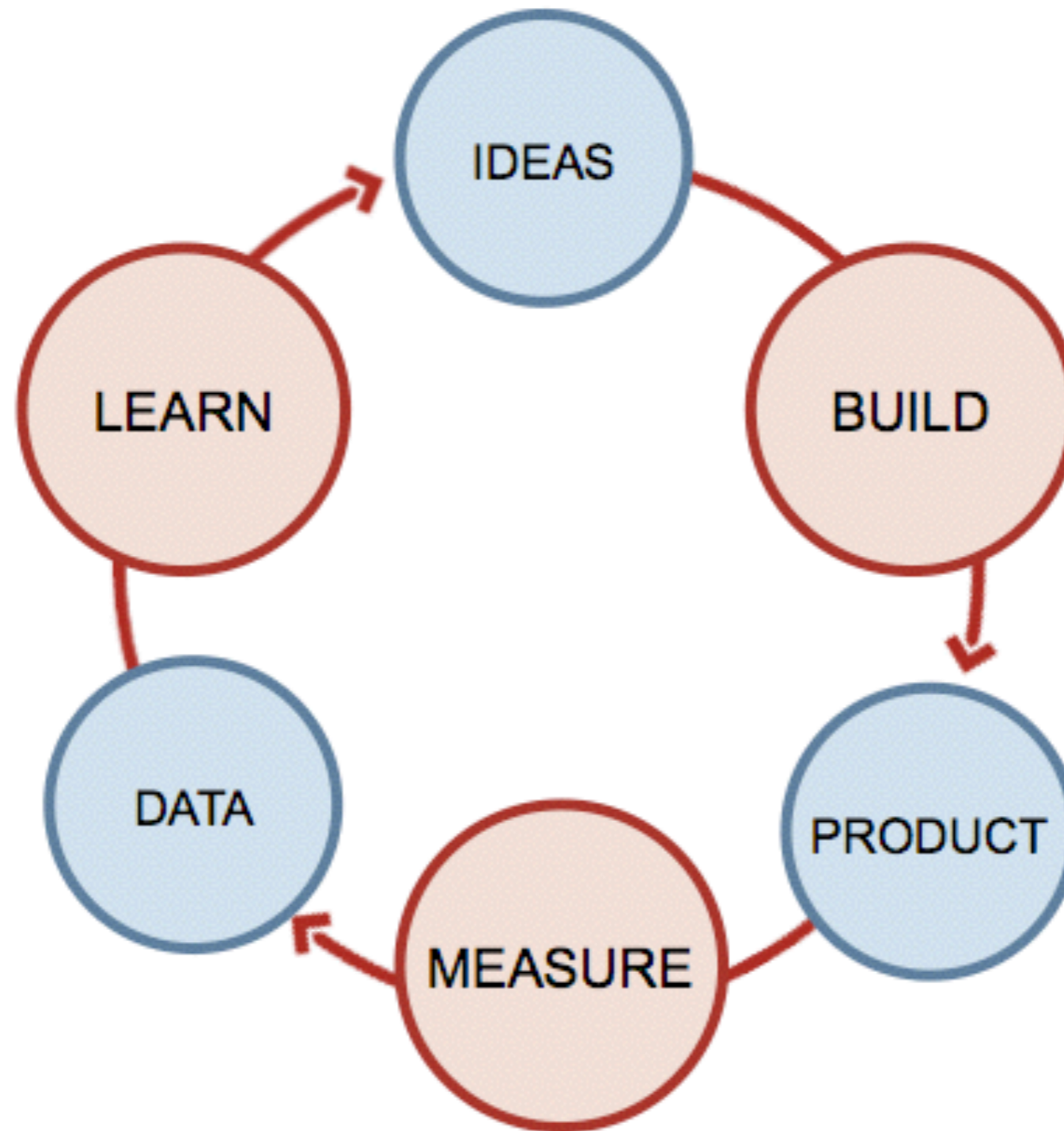

The LEAN Startup Approach

Designing Media

- The Vision of Designing Media
- Designing for Communities
- Branding and Design





- by providing the platform to the community individuals were able to create their own experiences
- content filtered through the community
- building trust through the interface design & branding
- branding as a success factor



Search

Browse

Upload

Create Account

Sign In

Join the largest worldwide video-sharing community!

[Create Account >](#)

Already have an account? [Sign In](#)

Music

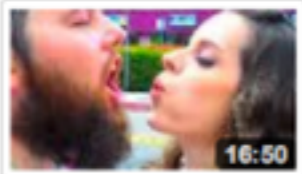

SO HOT!
by SHAYTARDS



B-e-a-utiful- Megan Nicole (Orig...
by megannicolesite

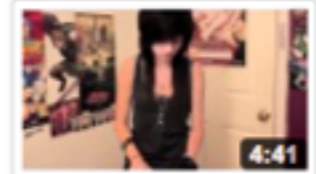

Me Singing "Skyscraper" by Demi
...
by zeldaxlove64



Rockzz aka King Katana - Mein Me...
by KILLABOZZZ

Entertainment



SEXY JULIA:
provokant und blond
by DieAussenseiter



BODY SHOTS
by BreakingNYC



Big Blue Ball Machine
by freddiew

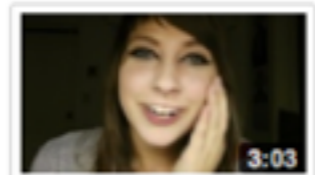

FOAR SVETLANA FRUM BOXXY
by boxxybabe

Sports



Basketballtipps vom Amateur
by realalbertson



Marco Huck vs Hugo Herman Garay ...
by ...



Türke gegen 200 Kg Riese Armdrüc...
by ClipTiger



LA Galaxy Vs Real Madrid (1-4) A...
by GoatzAndHighlights

Spotlight

Show Ad

Stolz auf unsere YouTube Partner

Wir freuen uns euch eine kleine Auswahl an neuen YouTube Partnern vorzustellen. Wenn du also glaubst, dass du das Zeug zum YouTube Partner hast, besuche unsere Partner Seite und melde dich einfach an.

Presented by: [dnewpartners](#)



Mein allererstes Mal auf Youtube - Willkommens-...
by douniaslimani
76,047 views



TRUESCHOOL - Stadtplatz Jam
by trueschoolofficial
3,153 views

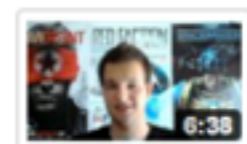
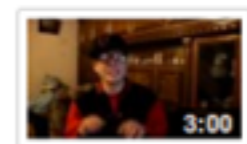

MODERN WARFARE 3 FÜR FARBENBLINDE!
by bashAchievements
846 views

Trends



Shark fights back against fisherman/ABC News
by aaaaaa4a
28,482 views



Let's Play Die Sims 3 #076 [Deutsch] [HD] - Neu...
by Gronkh
24,124 views

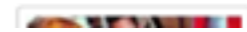

AI -GFAR - Miststück (Official

Service as Design Triangle:

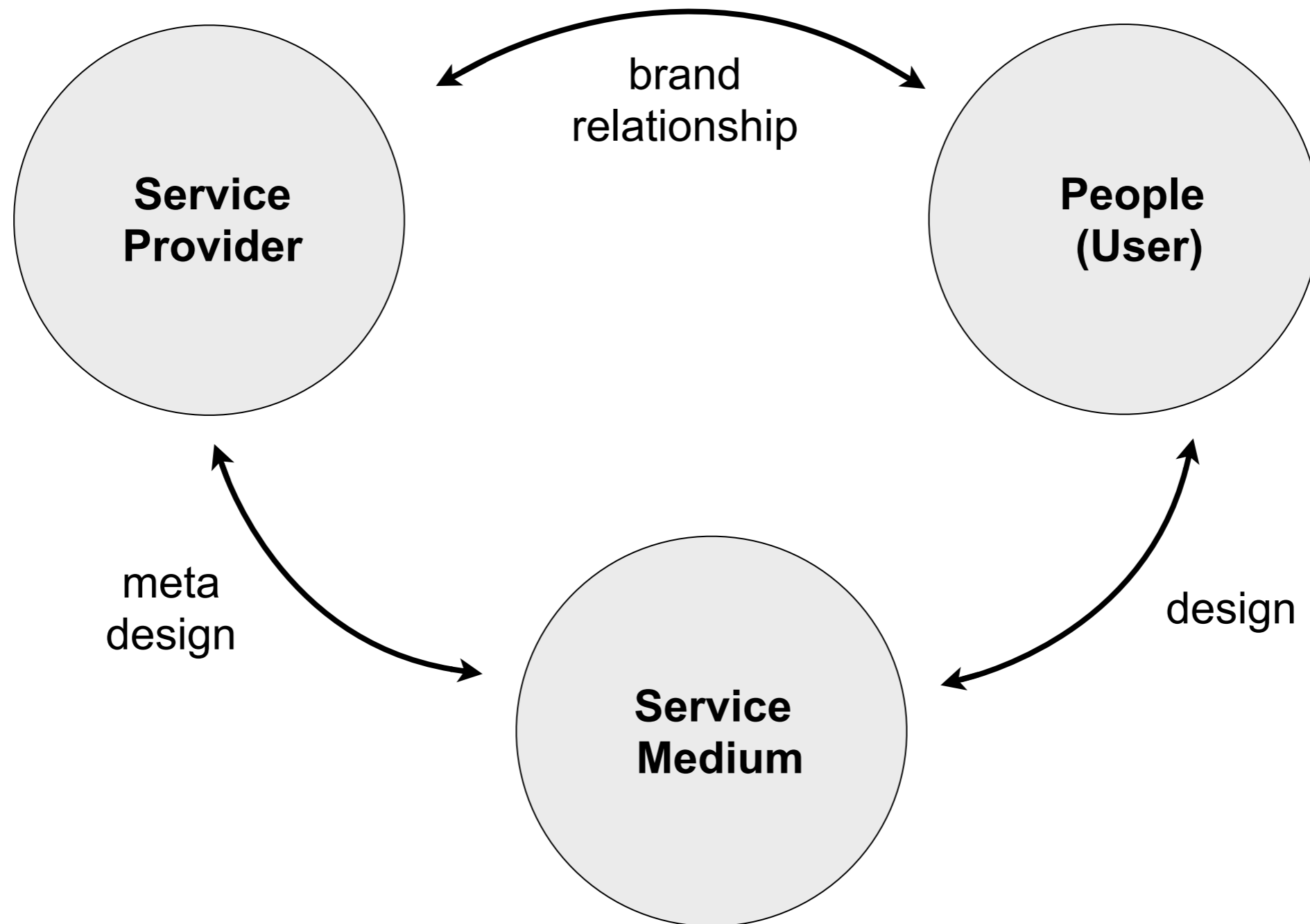

What we do
Watch our showreel

Airside by Airside
About our book

Work with us
Get in touch

Come out and Play
Our shop & feeds

NEWS

- 04.07.11 Junior Wanted – applications now closed.
- 23.06.11 Virgin's new In-Flight Entertainment system up and running
- 21.06.11 To The Victor, The Spoils! – premieres this week at Short & Sweet festival

FOLLOW US

- Twitter
- Flickr
- Vimeo
- Airside Blog RSS

NEWSLETTER

Name

Email

Sign me up

Recent work



Vitsœ

Website revamp for shelving systems company, Vitsœ.



- think about experiences rather than products
- only show people what they need to see
- think beyond the screen (e.g.return of the tangibility)
- add a “human touch” > be an advocate of the user

References (Books):

- [1] Buxton, W. Sketching User Experiences, *Morgan Kaufmann* 2007.
- [2] Norman, D. The Psychology of Everyday Things, *Basic Books* 2013.
- [3] Moggridge, B. Designing Interactions, *MIT Press*, 2006.
- [4] Moggridge, B. Designing Media, *MIT Press*, 2011.
- [5] Rogers, Y., Preece, J. & Sharp, H. Interaction Design, *Wiley & Sons* 2011.
- [6] Saffer, D. Designing for Interaction, *New Riders* 2009.
- [7] Lidwell, W.,: Universal Principles of Design, *Rockport*, 2003.